

# BASS-200

## active subwoofer

### Practical advice

When you are using an amplified speaker, one of the most important recommendations is to avoid at all costs a distorted input signal.

This means that when you are controlling the sound in the mixer (or any other preamplifier), you must avoid reaching saturation level. In the case of instruments it is advisable to keep the Gain control on a minimum, to control the volume with the fader (slider volume) for the channel; and to keep the master volume controls at around half way. During use of a microphone use the same principle as controlling the instrument, and adjust the Gain to increase the sensitivity of the microphone input.

In the case of amplified speakers, the arrival of a distorted signal (square wave) may damage the internal amplifier beyond repair, which may in turn damage the loudspeakers.

Correct use of speakers guarantees their long life.

Technical Specifications:	Construction:	Bass Reflex 10" woofer, with stereo filter input
	Power output:	200 watts continuous RMS / 300 watts peak (8 ohm / 0.10 % THD)
	Frequency response:	25 Hz – 200 Hz (-3dB)
	Maximum SPL:	117 dB
	Connections:	XLR in-out (left/right); 2 x crossoverized XLR out
	Power supply:	220 Vac 50 Hz / 115 Vac 60 Hz (manual switching)
	Safety:	Ground lift switch (anti-hum)
	Controls:	Volume
	Mounting:	ø36 mm std. Mount (top and bottom)
	Transport:	Two spring loaded carrying handles
	Dimensions:	320 x 360 x 380 (mm)
	Weight:	15.50 Kg (ca. 35 lbs.)

### Controls

#### Ground Lift switch

The ground Lift is a particularly useful tool when earth loops are produced. An earth loop is recognisable by a humming sound, which is normally heard as a background noise. This particular form of interference occurs when various instruments are connected to the same mains line and are connected to one other by audio signals. The Ground Lift breaks the earth in the circuit (not the earth connection proper), and in most cases succeeds in cutting out over 90% of the noise.

#### Stereo / mono switch :

By switching to STEREO the input sensitivity will decrease by -3dB

#### Volume

The volume control adjusts the maximum output level of the speaker.

# BASS-200

## active subwoofer

### Block diagram

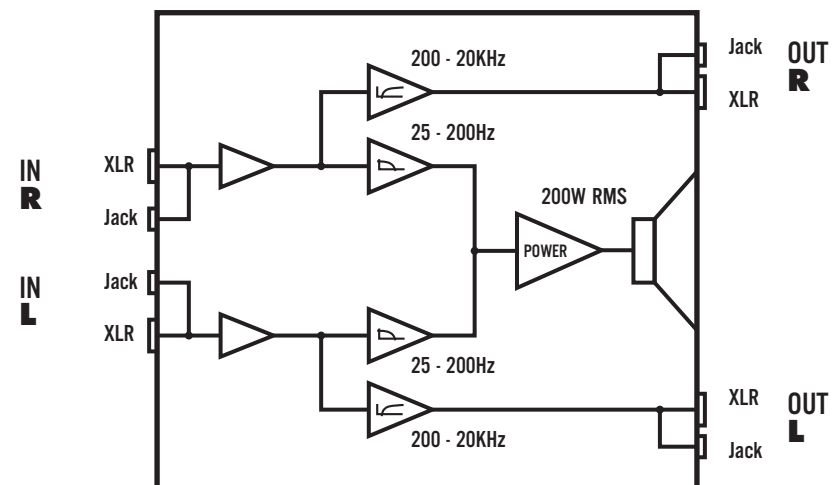

### Back Panel

