



MAG6 DYN AG6 - S MIC M	• USER • MANUAL	S W I S S	M A D E +
MULTI COIL MAGNETIC PICKUP FOR ACOUSTIC GUITAR			
	SCHERTLER		
V 1	WWW.SCHERTLER.COM		

INTRODUCTION

Congratulations on purchasing the SCHERTLER® MAGNETICO AG6. It is our pleasure to welcome you to a growing family of musicians and technicians, including many of the world's leading soloists and sound engineers, who have chosen to work with SCHERTLER® products.

The MAGNETICO AG6 is based on a completely different concept from standard single coil or humbucker pickups, uniquely combining our advanced Class-A electronics with active multiple coil technology. This results in a fast transient behavior, flat frequency response and a full rich sound across the entire range of the instrument. Two additional pickups have also been specially designed for use with the MAGNETICO AG6: the DYN AG6, which is ideal for percussive playing styles, and the S MIC M, which adds an extra dimension to your MAGNETICO sound.

All SCHERTLER contact microphones are developed and manufactured according to the highest standards of design, material quality and workmanship in order to ensure longevity. However, it is important to always handle your microphone with care so that it will provide reliable service.

In our continuing quest to improve the transmission and reproduction of acoustic instrument sound, we hope that the MAGNETICO AG6 will also enhance your personal performing or recording experience.

Stephan Schertler
and the SCHERTLER Team

MAGNETICO AG6 is a compact, lightweight pickup for acoustic guitar, designed to fit inside the instrument's soundhole. It has a master volume control and a gain control for a separate external input (EXT-IN), which can accommodate a second source such as the DYN AG6 electrodynamic contact microphone, or the compact S MIC M condenser mic. Sound from both inputs can be blended to create exactly the right effect for each individual performance or recording.

The pickup is supplied with an internal jack cable for fixed installation on the instrument. An external jack cable is available separately.

To make the most of your microphone's capability and to ensure trouble-free operation, please read this manual carefully before installation. We also advise keeping the manual for future reference.

SCHERTLER MAGNETICO AG6 - DYN AG6 - S MIC M: Made in Switzerland

FITTING THE PICKUP

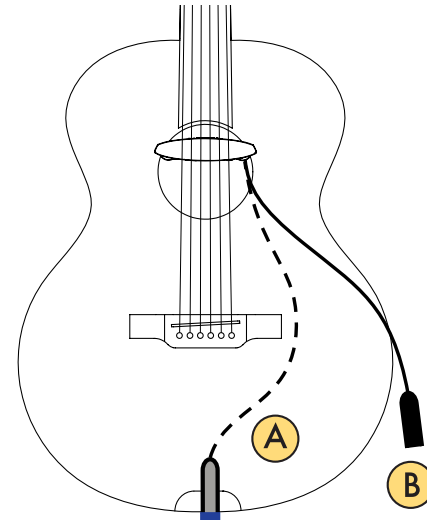
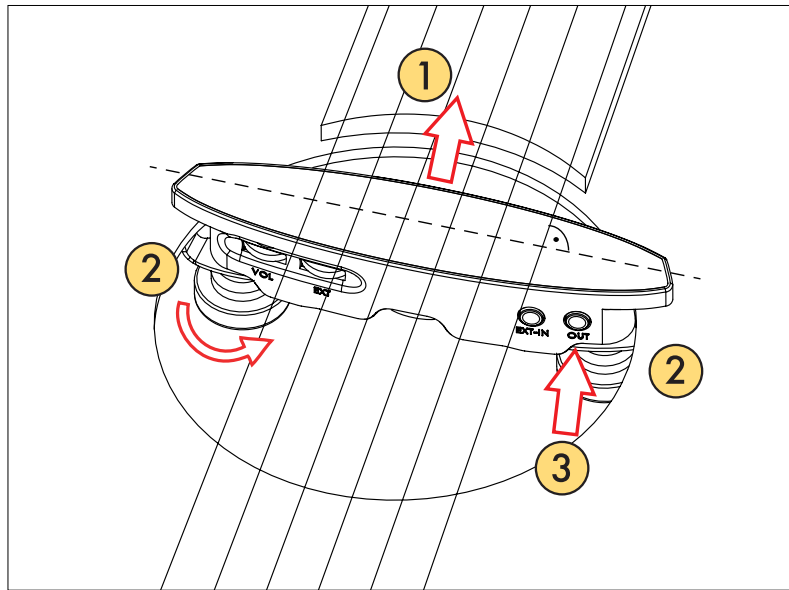

A. Internal endpin jack. Supplied
B. External female jack cable. Optional

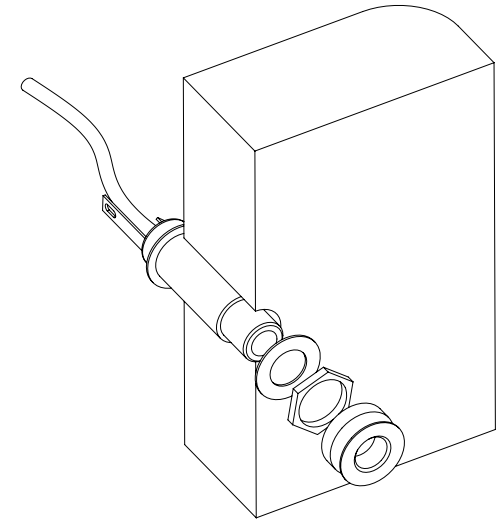

Endpin jack installation and assembly

Connecting the MAGNETICO AG6 to your guitar is simple and fast. You can install the pickup without removing the strings and you can fix it in three easy steps.

1. Position the MAGNETICO AG6 inside the soundhole and push it as close to the end of the fingerboard as possible. See picture above for reference. Make sure that the pickup is perpendicular to the strings.
2. Turn both wheels counter-clockwise to fix the pickup to the soundboard. Take care not to over-tighten the clamps or you may damage the guitar's finishing.
3. Connect the 1/8" jack cable to the output.

Now you can plug in your mono jack and discover the pickup's amazing sound.

To use the internal jack you must drill a 12 mm diameter hole into the guitar's tailblock. We suggest calling on a professional luthier if you are not qualified or experienced enough to do the work yourself. SCHERTLER cannot be held responsible for personal injury or damage to the instrument.

Note: The system will automatically switch on when you connect the mono jack to your guitar. Disconnect the cable if you are not playing for a while. This will prevent unnecessary battery discharge.

WARNINGS!

Plug and unplug the 1/8" jack connectors with caution, and only if necessary. These must be perfectly perpendicular when plugging/unplugging.

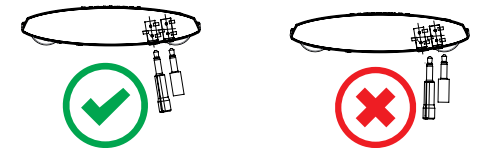

Any kind of phantom power or bias via the instrument cable can damage the M AG6. If you're using it with a SCHERTLER amp, preamp or mixer, be sure that the 10V function is turned OFF.

For optimal care, avoid using any cleaning products or solvents. Clean the M AG6 with a dry or slightly damp soft cloth (i.e. microfiber)

DYN AG6 RECOMMENDED POSITIONING

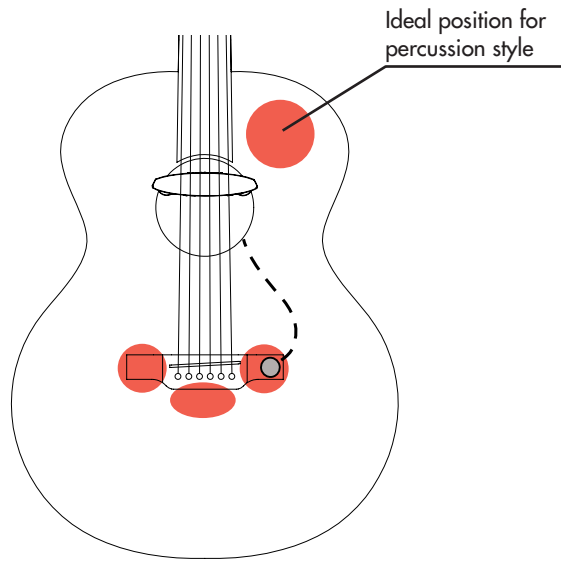

WARNING!
Fix your transducer by only applying glue on the inside of the guitar. Any glue used on external surfaces can damage the guitar's varnish.

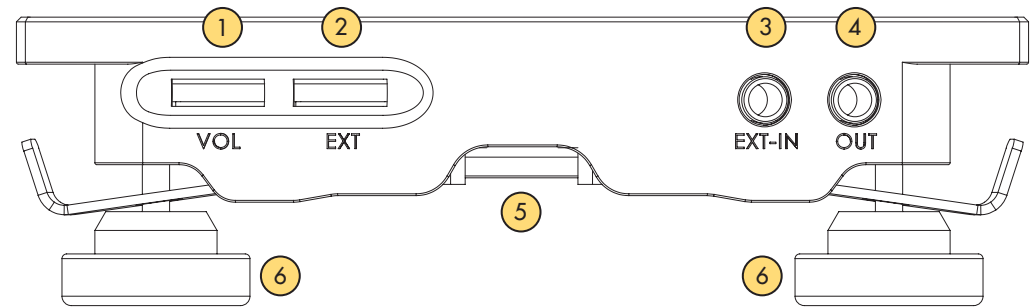

DYN AG6 is a moving coil contact microphone specially designed to complement the MAGNETICO AG6 sound.

Wide dynamic range and fast transient response are just some of the advantages of this unique SCHERTLER transducer. The ideal accessory for percussion style.

Plug the DYN AG6 into the EXT-IN 1/8" jack socket and position it as suggested inside your guitar. Use double-sided tape for temporary fixing and try out different positions to find the one that gives you the best sound, depending on your preferences or playing style. To permanently fix the microphone in place, use shoemaking or carpet glue.

Adjust the input gain of your DYN AG6 using the EXT potentiometer wheel. The sound will be added to that of the MAGNETICO pickup, enabling you to achieve the perfect blend required for each individual performance or recording.

The overall volume level from both pickups can be regulated using the VOL potentiometer.

- 1. VOLUME Potentiometer wheel for volume control (MAGNETICO AG6 + EXT-IN)
- 2. EXT Potentiometer wheel for external input gain control
- 3: EXT-IN 1/8" jack input for external sources (DYN AG6 or S MIC M)
- 4: OUT 1/8" jack output. Connect the supplied endpin cable (or the optional external jack cable)
- 5. BATTERY 3 V Lithium battery, model CR2032
- 6: WHEELS Clamping wheels for installation

NOTE: the MAGNETICO AG6 sound is always present. Using the EXT potentiometer, you can only add the sound from the EXT-IN (DYN AG6 or S MIC M) input to that of the MAGNETICO and balance the proportion of the two signals. It is not possible to mute the MAGNETICO sound and just hear the additional EXT-IN signal by itself.

S MIC M

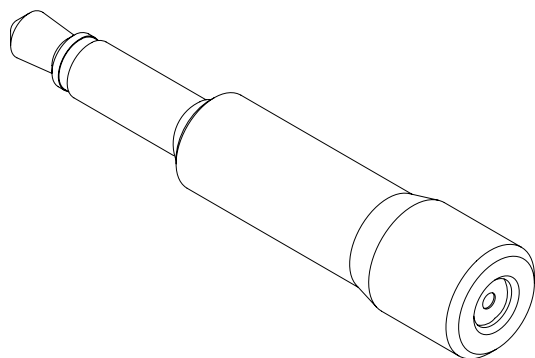

S MIC M is a compact condenser microphone that has been specially developed for use with the MAGNETICO AG6 pickup. Designed to add an extra dimension to the MAGNETICO sound, S MIC M can be directly connected to the EXT-IN input.

Adjust the input gain of your S MIC M using the EXT potentiometer wheel. The sound will be added to that of the MAGNETICO pickup, enabling you to achieve the perfect blend required for each individual performance or recording.

The overall volume level from both pickups can be regulated using the VOL potentiometer.

PICKUPS

ELECTRODYNAMIC

TECHNICAL INFORMATION

AG6

Transducer type	Magnetic multicoil active soundhole pickup
Output impedance	5 k Ω
EXT-IN impedance	ca. 10 k Ω
Frequency response (@ ± 3 dB)	0 to 40 kHz
Dynamic range	68 dB
Battery type	Lithium 3 V CR2032
Playing hours	c.a. 120 hours
Built-in preamp	Yes, all Class-A
For fixed installation	Yes
Removable	Yes
Connection	1/4" jack unbalanced output
Cable length	internal cable supplied
Minimum soundhole dimension	9 cm

S MIC M

Transducer type	Condenser back-electret
Output impedance	2.2 k Ω
Directivity	Omnidirectional
Frequency response (@ ± 3 dB)	60 Hz to 20 kHz
SPL max	128 dBA
Current consumption	0.3 mA
Operating voltage	3 to 10 VDC

DYN AG6

Transducer type	Electrodynamic moving coil passive contact microphone
Mechanical decoupling	Butterworth 2nd order
Frequency response (@ ± 3 dB) - filtered*	40 Hz to 12 kHz
Sensitivity	ca. -25 dBu
Dynamic range	94 dB
Output impedance	380 Ω
For fixed installation	Yes
Removable	No
Connection	Unbalanced via mono 1/8" jack
Cable length	23 cm

*Output frequency response is electronically filtered to better match the specific application.

FAQ

Is my setup correct?

For specific information on personal instrument compatibility or setup, please email our assistance service. Our specialists will be pleased to help you. You can find all our contacts in the footer of every SCHERTLER website page: www.schertler.com

I own a handmade guitar, will the MAGNETICO AG6 fit my soundhole?

The MAGNETICO AG6 enclosure is designed to fit into standard guitar soundholes with a minimum 9 cm diameter. Different soundhole diameters might change the final positioning of the pickup. (In any case, try to push it towards the neck side as much as possible.)

How can I clean the pickup?

For best results, clean the MAGNETICO AG6 with a slightly damp microfiber cloth. Avoid any cleaning product or solvent as they can damage the outer surface.

Can I use the MAGNETICO AG6 on a 7-string / 8-string guitar?

Unfortunately no. The core technology of the MAGNETICO AG6 is based on the 6 single coils, set to respond to the characteristics of each acoustic guitar string. Aside from missing one or two strings, the spacing and positioning of the strings would also be different, therefore the correct transduction of the sound would be compromised.

Can I use the MAGNETICO AG6 on a 12-string guitar?

In this case it is easier. Even if the transduction of the MAGNETICO AG6 alone wouldn't be optimal, this can be compensated for by using the DYN AG6 or the S MIC M to get a full, natural amplification of the 12-string sound.

The battery dies very quickly, is my MAGNETICO AG6 broken?

After many years and thousands of units sold, we can definitively state that there is no actual problem on the MAGNETICO AG6 that could cause a quick drain of the battery. However, one of the following instances might be contributing to this:

- You already had a pickup installed on your guitar and you're using the old endpin cable. The endpin cable provided with the MAGNETICO AG6 (blue cap) works as an ON/OFF switch when you plug/unplug the instrument cable to the guitar. A different endpin cable might keep the pickup "switched on", thus draining the battery in a few hours. Remove the old endpin cable and install the provided MAGNETICO AG6 one.

- In order to turn off the pickup, the instrument cable must be unplugged from the guitar, not just from the amp!

If used correctly, the MAGNETICO AG6 battery can provide around 120 hours of use.



APPENDIX

WARRANTY

All SCHERTLER products are covered by a limited two-year factory warranty in respect of manufacturer defects. Details can be obtained from your local dealer / representative.

SCHERTLER SA strongly believes in "common sense". Therefore, misuse of our products is not covered under rights obtained through our warranty policy, or through internationally recognized terms and conditions. For more information on warranty, please visit the General Condition's page at www.schertler.com

PRODUCT DISPOSAL

This product must not be disposed of in general household waste. It should be taken to a disposal center for electrical / electronic waste. Please note any local or national regulations that may be applicable here.

TRADEMARKS

The SCHERTLER® name and logo are registered trade names / trademarks of SCHERTLER SA Switzerland. All SCHERTLER® products use proprietary technology and are covered by one or more worldwide patents.

DISCLAIMER

All information and technical specifications published here are based on data that was available at the time of publication. SCHERTLER is, however, constantly aiming to improve its range of products and therefore reserves the right to amend product specifications and information without notice. SCHERTLER takes no responsibility for any direct or indirect damage (including loss of profit), which arises as a result of, or in connection with the information in this manual.

COPYRIGHT

This manual is the property of SCHERTLER SA and, as such, is subject to Swiss copyright law. No part of this manual should be reproduced, edited or distributed without prior consent from SCHERTLER.

