



CHARLIE
Jazz Guitar amplifier

IMPORTANT SAFETY INSTRUCTIONS



THE LIGHTNING FLASH WITH ARROWHEAD SYMBOL, WITHIN AN EQUILATERAL TRIANGLE, IS INTENDED TO ALERT THE USER TO THE PRESENCE OF UNINSULATED "DANGEROUS VOLTAGE" WITHIN THE PRODUCT ENCLOSURE THAT MAY BE OF A SUFFICIENT MAGNITUDE TO CONSTITUTE A RISK OF ELECTRIC SHOCK TO PERSONS.

THE EXCLAMATION POINT WITHIN AN EQUILATERAL TRIANGLE, IS INTENDED TO ALERT THE USER TO THE PRESENCE OF IMPORTANT OPERATING AND MAINTENANCE INSTRUCTIONS IN THE LITERATURE ACCOMPANYING THE PRODUCT.

WARNING

TO REDUCE THE RISK OF FIRE OR ELECTRICAL SHOCK
DO NOT EXPOSE THE APPLIANCE TO RAIN OR HUMIDITY

- 1) Read these instructions.
- 2) Keep these instructions.
- 3) Heed all warnings.
- 4) Follow all instructions.
- 5) Do not use this apparatus near water.
- 6) Clean only with dry cloth.
- 7) Do not block any ventilation openings. Install in accordance with the manufacturer's instructions.
- 8) Do not install near any heat sources such as radiators, heat registers, stoves, or other apparatus (including amplifiers) that produce heat.
- 9) Do not defeat the safety purpose of the polarized or grounding-type plug. A polarized plug has two blades with one wider than the other. A grounding type plug has two blades and a third grounding prong. The wide blade or the third prong are provided for your safety. If the provided plug does not fit into your outlet, consult an electrician for replacement of the obsolete outlet.
- 10) Protect the power cord from being walked on or pinched particularly at plugs, convenience receptacles, and the point where they exit from the apparatus.
- 11) Only use attachments/accessories specified by the manufacturer.
- 12) Use only with the cart, stand, tripod, bracket, or table specified by the manufacturer, or sold with the apparatus. When a cart is used, use caution when moving the cart/apparatus combination to avoid injury from tip-over.
- 13) Unplug this apparatus during lightning storms or when unused for long periods of time.
- 14) Refer all servicing to qualified service personnel. Servicing is required when the apparatus has been damaged in any way, such as power-supply cord or plug is damaged, liquid has been spilled or objects have fallen into the apparatus, the apparatus has been exposed to rain or moisture, does not operate normally, or has been dropped.



INTRODUCTION

Schertler's CHARLIE is an exciting new compact electric amplifier that has been specifically developed for use with jazz guitar. The single channel, 280W amp is designed to enhance the delicate low-mid range of the instrument, which often features more prominently in a conventional jazz line-up. When played through a standard guitar amp, those particular frequencies on the instrument can appear "muddy" with compressed harmonics. In contrast, CHARLIE is designed to offer maximum intelligibility in that range. Equipped with a Class A preamp, an uncompromising speaker/power amp combination and traditional spring reverb, CHARLIE delivers a warm, clear sound that gives the jazz guitar its true voice in any ensemble.

1.FRONT

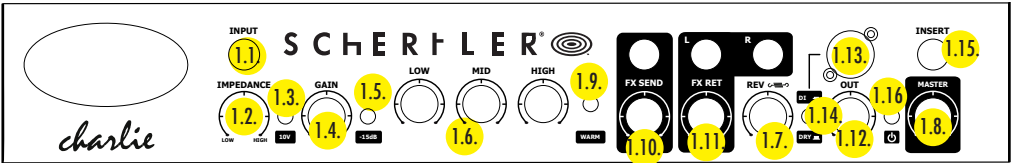

1.1. INPUT

Unbalanced input for the connection of jacks (6,3mm or 1/4")

1.2. IMPEDANCE

Matches the impedance from 22Kohm to 2Mohm (adjustable)

1.3. 10V

Phantom power supply with 10V for powering electret microphones and Schertler STAT, Basik and Lydia series.

1.4. GAIN

This variable gain preamplifier adjusts the sensitivity level to ensure the best possible processing of the signal through the channel. It is important that this input level must be set and optimised in the best way to achieve the cleanest sound possible.

1.5. - 15 dB (PAD)

If the input signal from jack input is too powerful and you have overloads, use the PAD switch to have 15dB reduction.

1.6. HIGH, MID, LOW

These controls are devoted to high, mid and low frequency regulation. Offering cut and boost of +/- 15dB, they allow a wide range of tonal variations to be explored. When the controls are positioned centrally there is no cut or boost of the selected frequency band.

1.7. REVERB

This rotary control sets the level of the spring reverb on the individual channel.

1.8. MASTER

This rotary control regulates the master volume.

1.9 WARM

When engaged, this low-pass filter damps higher frequencies to produce a warmer sound when using bridge-mounted pickups such as Schertler STAT-series.

1.10 FX SEND

This rotary control sets the output level on the SEND OUT.

1.11 FX RET

This rotary control sets the input level on the stereo RETURN IN.

1.12 OUT control

This rotatory control sets the output level on the DI out

1.13 OUT connector

General output. XLR balanced type connector for connection of external systems.

1.14 DI DRY switch

If not switched the output signal is DRY (pre eq), or post-eq (DI) if switched

1.15 INSERT

This stereo jack plug enables the connection of an external device (compressor, equalizer, etc) in series to the input

1.16 MUTE

2. BACK

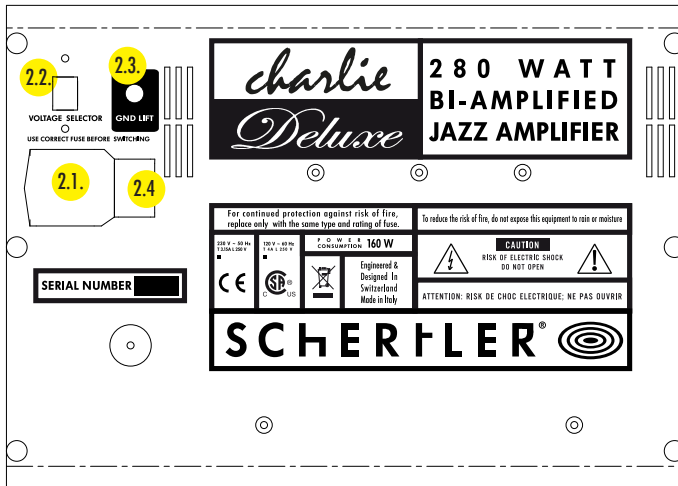

2.1. MAIN POWER CONNECTION

Connection to mains (230V AC/120V AC 50Hz/60Hz)

PLEASE ENSURE THE PROPER VOLTAGE AND USE THE ORIGINAL CONNECTION CABLE!

2.2. NET SWITCH

This switch changes the main power voltage from 230V AC to 120V AC

2.3. GROUND LIFT

This switch connects and disconnects the ground between source and amplifier. Use this switch to suppress hum caused by the power mains

2.4. POWER ON/OFF

3. BLOCK DIAGRAM

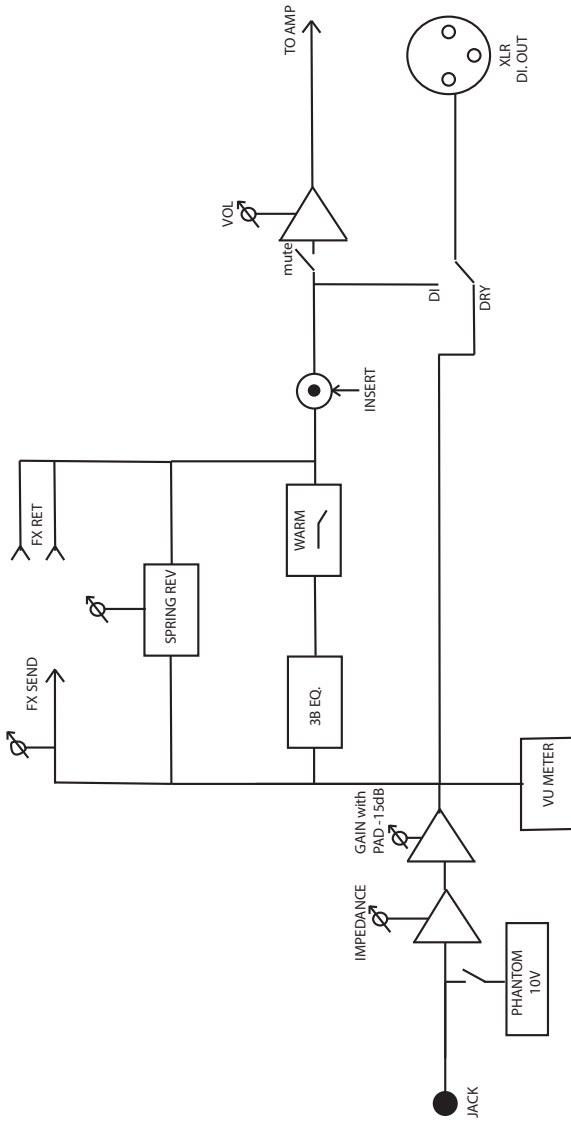

WARNINGS

PRECAUTIONS

WARNING

Read carefully this manual and follow these precautions before operating the device

Keep this manual for possible future needs

Pay attention not to pour liquids onto the device and do not operate in conditions of excessive humidity

Do not install the device close to sources of excessive heat, do not expose it to direct solar radiation and do not position it without protection in a dusty environment

Be sure that the mains voltage does not exceed the value indicated on the back panel

Do not use the device if the mains cable or the plug aren't in a perfect condition (if necessary, replace it)

If the mains cable has to be replaced, the operation must be carried out by qualified personnel. Replace the cable exclusively with one that is an exact substitute

In order to avoid interference, do not install the device close to power transformers, TV sets, RF transmitters, electric motors or any source of electric energy

Do not point microphones against speakers: this could generate annoying whistles (Larsen effect) that cause damage

In order to avoid unpleasant and costly inconveniences, use only original connecting cables

To completely disconnect this apparatus from the AC mains, disconnect the power supply cord plug from the AC socket

When cleaning, do not use solvents (e.g. acetone or alcohol). These could damage the external finishing and the serigraphy

Do not attempt to service this product. In case of malfunction of any part of the system call the nearest technical assistance centre or a specialized technical centre

For good ventilation, the dissipation vents should never be covered or obstructed by blankets, sofas or similar furniture. Be sure also to leave sufficient clearance between the dissipation vents and any other surface

No source of flames, e.g. candles, should be placed on or near the device

The device should not be exposed to water, even in small amounts. No object containing liquids should be placed on or near the device

The device should only be connected to a mains socket outlet equipped with protection ground system

When the device is installed, be sure the mains socket and the plug of the mains cable are easily accessible

4. TECHNICAL DESCRIPTION

4.1. DESCRIPTION

Box two way, bass reflex

4.2. ENCLOSURE SECTION

Construction: BIRCH Plywood

Weight: 24kg

Dimensions: 53cm x 25cm x 41.5cm

4.3. AMPLIFIED SPEAKER SECTION

Freq. resp.: 40Hz - 20kHz (-3dB)

Sensitivity: 95.6dB

SPL max: 118dB

4.4. TECHNICAL SPECIFICATIONS INPUTS

Connector: JACK 6.3mm unbalanced

Sensitivity: -47dB

Impedance: 22kohm to 2Mohm @1KHz

4.5. TECHNICAL SPECIFICATIONS OUTPUTS

FX SEND

Connector: JACK 6.3mm balanced

Level: 0dBu

Impedance: 100ohm

DI OUT

Connector: XLR balanced

Level: -15dBu

Impedance: 220ohm

RETURN

Connector: JACK 6.3mm balanced

Level: 0dBu

Impedance: 22Kohm

4.6. INTERNAL EFFECT (spring reverb)

Freq. resp.: 200Hz - 10KHz (-3dB)

PreDelay time:c.a. 30ms

Reverb time: c.a. 2s

4.7. COMPONENTS

Woofers: 10"

Tweeter: Dome 1"

Cross-over: Active, 24dB/octave

Amplifier: 200W + 80W

ALL SCHERTLER® PRODUCTS ARE COVERED BY A LIMITED TWO-YEAR WARRANTY (FROM THE DATE OF PURCHASE) AGAINST MANUFACTURES DEFECTS. DETAILS CAN BE OBTAINED FROM YOUR LOCAL DEALER/REPRESENTATIVE. SCHERTLER SA STRONGLY BELIEVES IN "COMMON SENSE" AND THUS, MISUSE OF OUR PRODUCTS ARE NOT COVERED UNDER RIGHTS OBTAINED THROUGH OUR WARRANTY POLICY OR THAT OF INTERNATIONALLY RECOGNIZED TERMS AND CONDITIONS.

SCHERTLER SA IS CONSTANTLY AIMING TO IMPROVE ITS RANGE OF PRODUCTS THEREFORE, SCHERTLER SA RESERVES THE RIGHT TO AMEND PRODUCT SPECIFICATIONS WITHOUT NOTICE.

THE SCHERTLER® NAME/LOGO ARE REGISTERED TRADE-NAMES/ TRADEMARKS OF SCHERTLER SA, SWITZERLAND. ALL SCHERTLER® PRODUCTS ARE OF PROPRIETARY TECHNOLOGY AND COVERED BY ONE OF MORE WORLDWIDE PATENTS.



SCHERTLER®

ACOUSTIC AMPLIFICATION

SWISS MADE

schertler.com



TEL+41916300710

FAX+41916300711

info@schertler.com

SCHERTLER SA

Via Beroldingen 18

6850 Mendrisio